

"HCWB" / Low cost Washer type



Features

- High reliability. Washer type load cells of versatile applications.
- Abundant sales achievements. Low costs.
- A wide range of rated capacities (30kN to 500kN).
- Applications: Ejection type moulding machines and press machines. For measurement of tension in bolts.
- Accuracy class: 1%.

Related products : HCW...

Appearance Dimensions

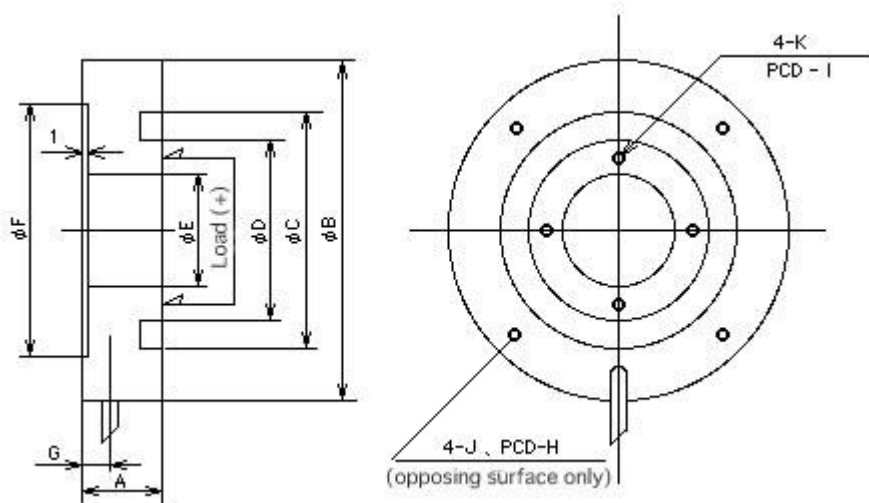

Model and Capacity / Dimension / etc. (unit : mm)

Model	Capacity	A	B	C	D	E	F	G	H	I	J/K	Weight
HCWB-30KN	30kN	28	117	85	65	40	90	9.5	104	52	M5,10 deep	1.6kg
HCWB-50KN	50kN	28	155	124	102	72	128	9.5	140	87	M6,12 deep	2.5kg
HCWB-100KN	100kN	32	198	156	134	90	163	10	182	112	M6,12 deep	5.0kg
HCWB-200KN	200kN	40	220	180	156	110	188	12	198	132	M6,12 deep	7.2kg
HCWB-300KN	300kN	50	285	233	205	145	238	15	260	170	M6,12 deep	15kg
HCWB-500KN	500kN	50	335	285	255	200	290	15	310	230	M6,12 deep	18kg

- * Items are produced only on order placed.
- * Contact the manufacturer in regard to detailed dimensions.

Specifications

Safe Overload	150%RC
Rated Output	1mV/V±1%
Nonlinearity	1%RO
Hysteresis	1%RO
Repeatability	0.3%RO
Excitation Voltage	10V (or less)
Safe Excitation Voltage	15V
Input Resistance	350Ω
Output Resistance	350Ω
Compensated Temp.Range	-10 to 60°C
Safe Temp.Range	-20 to 80°C
Temp.Effect on Zero	0.01%RO/°C
Temp.Effect on Output	0.01%/°C
Cable	Φ6mm-4wire shielded cable, length : 0.5m
Attached connector	Jack / PRC03-32A10-7F
Attached cable	L-A-5 (Refer to transducer connections)