

# ENCARDIO RITE



## INTRODUCTION

Encardio-rite model ELC-30S resistive strain gage type centre hole load cell is extensively used to determine load in rock bolts, tiebacks, foundation anchors, cables or struts depending on the application. It is also used for compressive load measurement between structural members i.e. tunnel supports or at the junction between a beam and the top of a pile strut.

The Encardio-rite model ELC-30S is a precision engineered load cell with a central cylindrical hole. It is specially designed for civil engineering applications. It is available in capacities ranging from 200 kN to 2000 kN.



## OVERVIEW

The center hole load cell comprises of a element of high strength martensitic stainless steel. It uses eight 350 Ohm resistance strain gages, wired to form a 700 Ohm bridge. To minimize the effect of uneven and eccentric loading, the eight strain gages are mounted at 45° to each other in a groove at the base of a stainless steel columnar element. Load applied to the cell can be measured by using any standard digital read-out unit suitable for resistance strain gage applications.

The strain gages are mounted in a groove at the base of a stainless steel columnar element. A stainless steel diaphragm is electron beam welded to the element to cover the groove resulting in a vacuum of around 1/1000 Torr inside the sensor. All this helps in sensor becoming immune to atmospheric corrosion and effect of ingress of water. The sectional area of the columnar element and the depth of the groove in it is varied in different capacity load cells to give approximately the same mV/V output for a variation of zero to full load.

## FEATURES

- ✦ Rugged & robust construction
- ✦ Suitable for hostile & severe environment
- ✦ Temperature compensated
- ✦ Hermetically sealed by electron beam welding
- ✦ Eight strain gages incorporated to reduce positioning effect

Any standard strain gage bridge measuring read out device can be used

## APPLICATIONS

- ✦ To determine load in rock bolts, tiebacks, foundation anchors, cables or struts
- ✦ Proof testing and long term performance monitoring of different kind of anchor systems
- ✦ Compressive load measurement between structural members i.e. tunnel supports or at the junction between a beam and the top of a pile strut
- ✦ Used extensively for correlating data obtained from bore hole extensometers

## DIMENSIONS

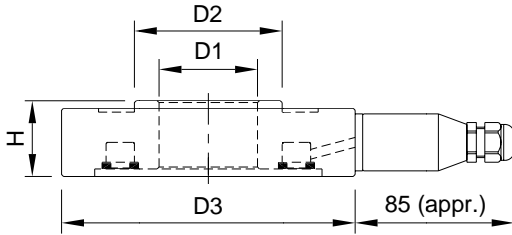

## ORDERING INFORMATION

Model **ELC-30S- X/Y**

Capacity kN/ID \_\_\_\_\_

## TYPICAL INSTALLATION

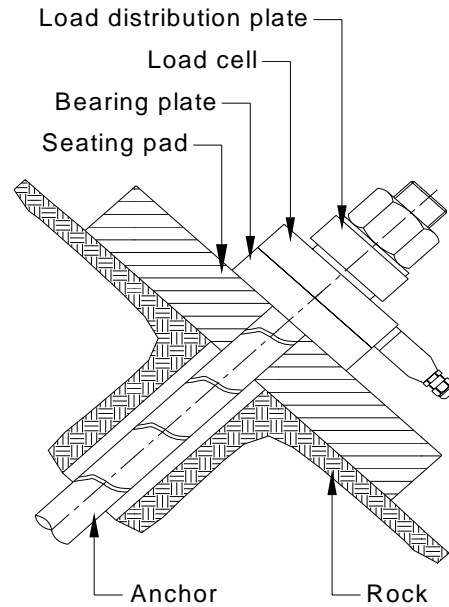

## SPECIFICATIONS

Type	Resistive strain gage
Range (kN/ID mm)	200/40, 500/52, 1000/78, 1000/105, 1500/85, 1500/130, 2000/105, 2000/155 or as specified
Over range capacity	150 %
Calibration accuracy	± 0.25 % fs
Non-linearity	± 1 % fs
Output	2 mV/V ± 10 %
Excitation	10 V DC (max. 20 V DC)
Terminal resistance	
Input	770 Ohm ± 5 %
Output	700 Ohm ± 1 %
Temperature limit	-20 to 80°C
Cable connection	Six pin glass to metal seal

*\*All specifications subject to change without prior notice.*

Capacity kN	Centre hole load cell					Plate T mm	Bearing plate			Load distribution plate		
	D1 mm	D2 mm	D3 mm	Ht. mm	Wt. kg		OD mm	ID mm	Wt. kg	OD mm	ID mm	Wt. kg
200	40	60	155	40	5	23	155	116	2	75	40	1
500	52	78	155	40	5	35	155	116	2.5	98	52	1.5
1000	78	116	200	40	7	45	200	150	5	135	78	3.5
1000	105	138	225	40	8	45	225	172	6	155	105	4
1500	85	130	225	55	12	55	225	165	8	150	85	5.5
1500	130	165	260	55	14.5	55	260	200	9.5	180	130	5.5
2000	105	160	260	55	16	65	260	195	12	180	105	9
2000	155	192	260	55	12.5	65	260	226	7	210	155	8.5

## ENCARDIO-RITE ELECTRONICS PVT. LTD.

A-7 Industrial Estate, Talkatora Road, Lucknow, UP-226011, India

P +91 522 2661040, F +91 522 2662403, geotech@encardio.com

International: P +91 522 2661044, www.encardio.com

DATA SHEET 1102-12 R02