

"DBV" / Loads Cell with amplifier



Features

- With built-in amplifier. Output to be +/- 10 V. Low cost version.
- Input power supply: 12 V DC (10 to 15 V), 50 mA.
- Complete with span, zero, and tare adjusting trimmer.
- For both tension and compression applications. Excellent linearity: 0.1%RO.
- Meeting the high rated capacity requirement (200N to 10 kN).

Related products : ["PSD" / Loads Cell with amplifier](#)

Appearance Dimensions

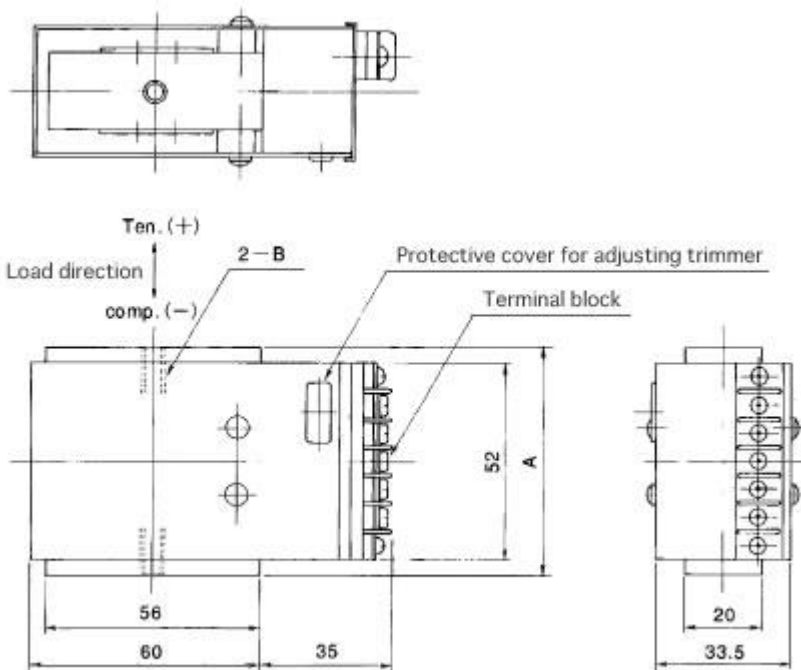

Model and Capacity / Dimension / etc. (unit : mm)

Model	Capacity	A	B	Weight
DBV-200N	200N	60	M6*1,12 deep	650g
DBV-500N	500N	60	M6*1,12 deep	650g



DBV-1KN	1kN	60	M6*1,12 deep	650g
DBV-2KN	2kN	70	M12*1.75,16 deep	650g
DBV-5KN	5kN	70	M12*1.75,16 deep	650g
DBV-10KN	10kN	70	M12*1.75,16 deep	650g

Specifications

Safe Overload	150%RC
Rated Output	±10V (Minimum load resistance: 2kΩ)
Nonlinearity	0.1%RO
Hysteresis	0.1%RO
Repeatability	0.05%RO
DC power supply	12VDC (10 to 15V) 50mA
Compensated Temp.Range	0 to 40°C
Safe Temp.Range	-10 to 50°C within 80%RH (Excluding condensations)
Temp.Effect on Zero	0.01%RO/°C
Temp.Effect on Output	0.01%/°C